

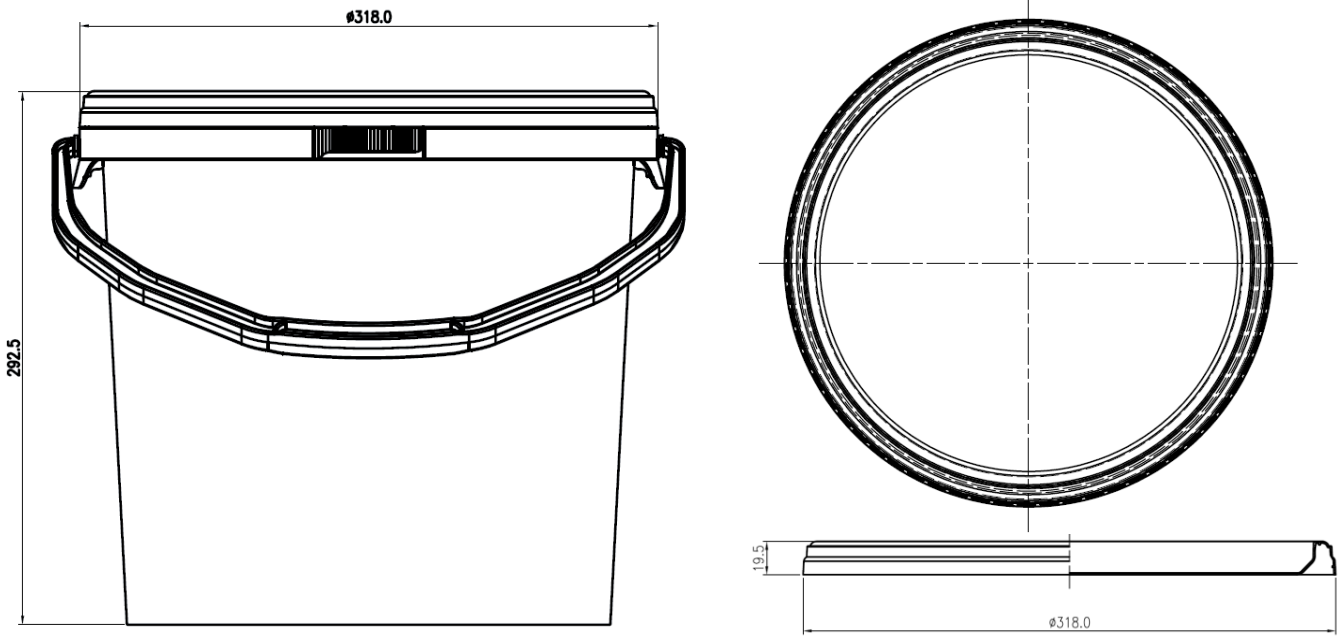

Shalam Packaging Ltd.



15 litre BUCKET

Tamper Evident

MATERIAL	Food Grade Polypropylene Co-Polymer, option of recycled content. Polypropylene is a recyclable plastic.		
HANDLE TYPE	Plastic or metal		
COLOUR	White – a range of colours are available on request		
DECORATION	In Mould Labeling available on request		
BRIM VOLUME	17.7 Litres		
WEIGHT		Virgin PP:	Recycled content PP(min 30%):
	Container:	485g (+/- 15g)	534g (+/- 22g)
	Lid:	95g (+/- 5 g)	105g (+/- 8 g)
	Plastic handle:	27g (+/- 1 g)	
	Metal handle:	47g (+/- 2 g)	
QUANTITY (EMPTY)	Container:	308 per pallet (1000mm x 1200mm)	
	Lid:	770 per pallet	
STACKING (EMPTY)	Container:	3 pallets high	
	Lid:	in pallet box 3 high	
FILLING (Based on product density 1.4 air temperature 20°C)	44 per pallet (11 per layer x 4 high) This is equivalent to a maximum weight of 63kg on the lower bucket Maximum stacking temperature 40°C. 1250 mm maximum pallet height		
FILL TEMPERATURE	Standard blend max 80°C Hotfill max 121°C	avoid prolonged exposure over 40°C and below -20°C avoid prolonged exposure over 100°C and below 10°C	
	Polymer blend can be adjusted to suit other temperatures. Stacking performance is affected by temperature, do not stack hot. Guide temperatures: performance is affected by temperature profile and product.		
COMPATIBILITY	It is the responsibility of our customers to ensure their product is compatible with the container. Trials can be carried out by Shalam on request.		

All details correct at the time of printing. Please contact us for additional technical, sales and order assistance.

Shalam Packaging Ltd., Pipp's Hill Industrial Estate, Bentalls, Basildon, Essex SS14 3BX

Tel +44 (0)8445 611 566

sales@Shalampackaging.com
www.Shalampackaging.com

