

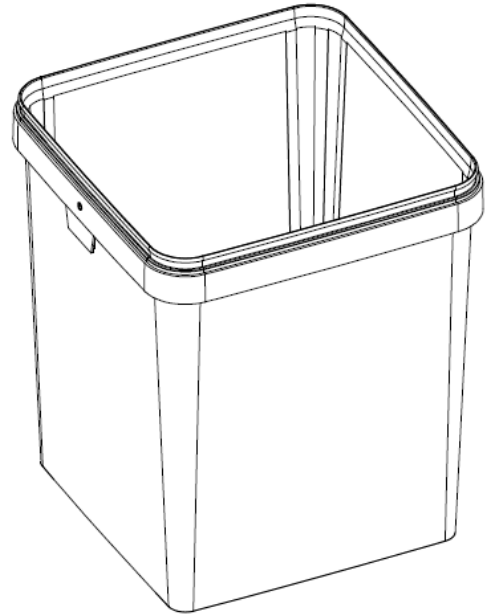

Shalam Packaging Ltd.

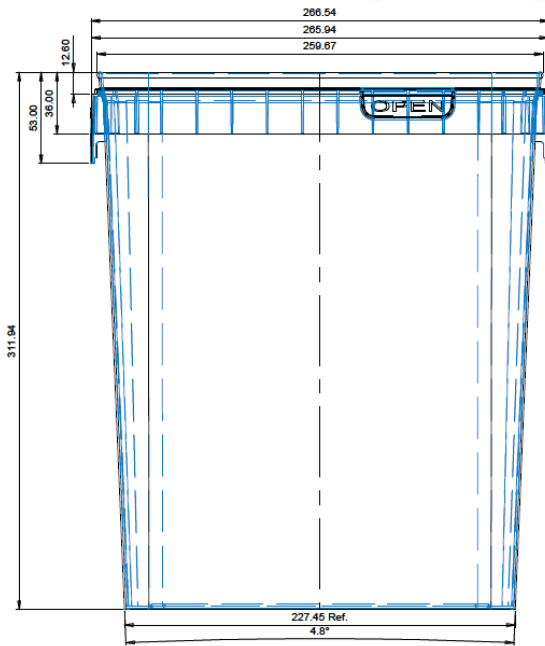

17 LITRE SQUARE BUCKET Tamper Evident

MATERIAL	Food Grade Polypropylene Co-Polymer		
HANDLE TYPE	Plastic		
COLOUR	White – a range of colours are available on request		
LABELING	In Mould Labeling available on request		
BRIM VOLUME	17.35 Litres		
WEIGHT	Container:	450g (+/- 25g)	
	Lid:	100g (+/- 7 g)	
	Plastic handle:	35g (+/- 1g)	Metal handle: 47g (+/- 2 g)
QUANTITY (EMPTY)	Container:	312 per pallet (1000mm x 1200mm) TBC	
	Lid:	720 per pallet TBC	
		Lids and buckets dairy wrapped for food standards	
STACKING (EMPTY)	Container:	3 pallets high	
	Lid:	in pallet box 3 high	
FILLING (Based on product density 1.4 air temperature 20°C)	48 per pallet (12 per layer x 4 high)		
	This is equivalent to a maximum weight of 70kg on the lower bucket.		
	Maximum stacking temperature 40°C		
	1350 mm maximum pallet height TBC		
FILL TEMPERATURE	Standard blend Max 70°C avoid prolonged exposure over 40°C and below -20°C		
	Hotfill max 95°C avoid prolonged exposure over 65°C and below 15°C		
	Extra hot fill Max 121°C avoid prolonged exposure over 100°C and below 10°C		
	Freezer max 50°C avoid prolonged exposure over 30°C and below -30°C		
	Polymer blend can be adjusted to suit other temperatures.		
	Stacking performance is affected by temperature, do not stack hot.		
COMPATIBILITY	It is the responsibility of our customers to ensure their product is compatible with the container. Trials can be carried out by Shalam on request.		

All details correct at the time of printing. Please contact us for additional technical, sales and order assistance.

Shalam Packaging Ltd., Pippis Hill Industrial Estate, Bentsalls, Basildon, Essex SS14 3BX Tel +44 (0)8445 611 566

sales@Shalampackaging.com www.Shalampackaging.com



J. Meredith