

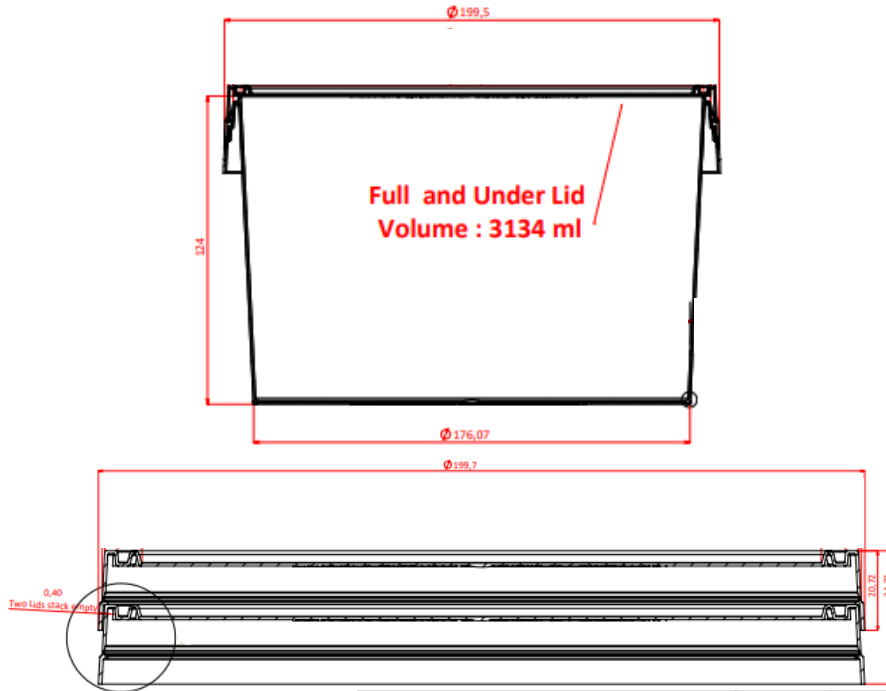

Shalam Packaging Ltd.



# 2.5L BUCKET Mould 2

Tamper Evident

MATERIAL	Food Grade Polypropylene Co-Polymer	
HANDLE TYPE	Plastic or metal	
COLOUR	White – a range of colours are available on request	
DECORATION	In Mould Labeling available on request	
BRIM VOLUME	3.13 Litres	
WEIGHT	Container:	97g (+/- 10g)
	Lid:	34g (+/- 4 g)
	Plastic handle:	7.5g (+/- 1 g)
QUANTITY (EMPTY)	Container:	1,170 per pallet (1000mm x 1200mm)
	Lid:	1,375 per pallet
	Lids and buckets dairy wrapped for food standards	
STACKING (EMPTY)	Container:	3 pallets high
	Lid:	in pallet box 3 high
FILLING (Based on product density 1.4 air temperature 20°C)	150 per pallet (25 per layer x 6 high) This is equivalent to a maximum weight of 17.5kg on the lower bucket Maximum stacking temperature 40°C 1150 mm maximum pallet height	
FILL TEMPERATURE	Max 80°C (avoid prolonged exposure over 40°C and below -20°C) tbc Polymer blend can be adjusted to suit other temperatures.	
COMPATIBILITY	It is the responsibility of our customers to ensure their product is compatible with the container. Trials can be carried out by Shalam on request. Stacking performance is affected by temperature, do not stack hot.	

All details correct at the time of printing. Please contact us for additional technical, sales and order assistance.

Shalam Packaging Ltd., Pippis Hill Industrial Estate, Bentsalls, Basildon, Essex SS14 3BX

Tel +44 (0)8445 611 566

sales@Shalampackaging.com  
www.Shalampackaging.com



2.5L M2 bucket customer specification	Page 1/1	Issued by J.Meredith <i>J. Meredith</i>	20/04/22	V1.1
---------------------------------------	----------	---	----------	------