

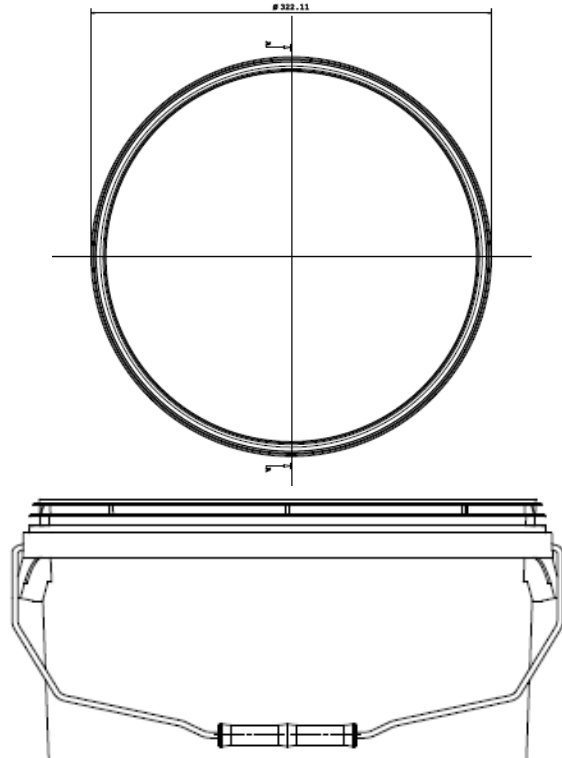

Shalam Packaging Ltd.

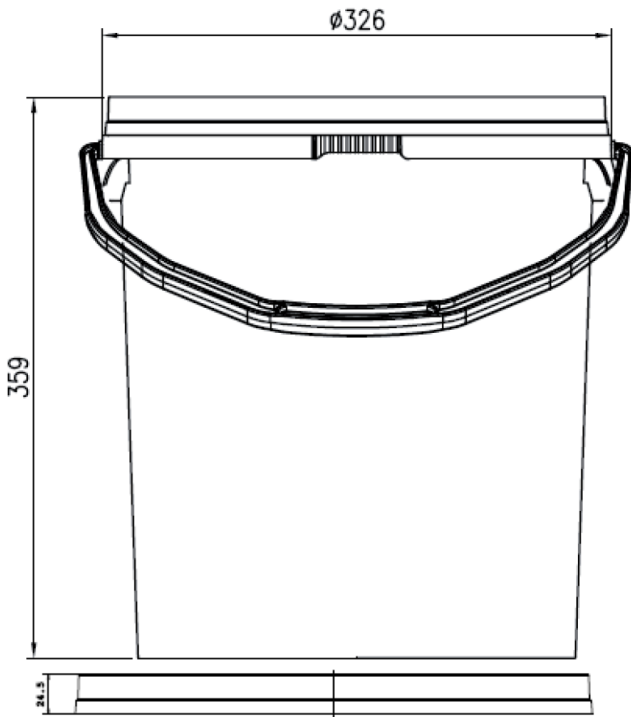

# 20 ltr BUCKET

Tamper Evident

<b>MATERIAL</b>	Food Grade Polypropylene Co-Polymer		
<b>HANDLE TYPE</b>	Plastic or metal		
<b>COLOUR</b>	White – a range of colours are available on request		
<b>DECORATION</b>	In Mould Labeling available on request		
<b>BRIM VOLUME</b>	23.04 Litres		
<b>WEIGHT</b>	<b>Container:</b> 625g (+/- 34g) <b>Lid:</b> 110g (+/- 7 g) <b>Plastic handle:</b> 27g (+/- 1 g)	<b>Cover lid:</b> 100g (+/- 7 g) <b>Metal handle:</b> 47g (+/- 2 g)	
<b>QUANTITY (EMPTY)</b>	<b>Container:</b> 170 per pallet (1000mm x 1200mm) <b>Lid:</b> 550 per pallet		
<b>STACKING (EMPTY)</b>	<b>Container:</b> 3 pallets high <b>Lid:</b> in pallet box 3 high		
<b>FILLING (Based on product density 1.4 air temperature 20°C)</b>	40 per pallet (10 per layer x 4 high) This is equivalent to a maximum weight of 84kg on the lower bucket Maximum stacking temperature 40°C. 1500 mm maximum pallet height		
<b>FILL TEMPERATURE</b>	Standard blend max 80°C Freezer blend max 60°C Hotfill max 121°C Extra hotfill max 130°C	avoid prolonged exposure over 40°C and below -20°C avoid prolonged exposure over 30°C and below -30°C avoid prolonged exposure over 100°C and below 10°C avoid prolonged exposure over 100°C and below 10°C	
	Polymer blend can be adjusted to suit other temperatures. Stacking performance is affected by temperature, do not stack hot.		
<b>COMPATIBILITY</b>	It is the responsibility of our customers to ensure their product is compatible with the container. Trials can be carried out by Shalam on request.		

All details correct at the time of printing. Please contact us for additional technical, sales and order assistance.

Shalam Packaging Ltd., Pipp's Hill Industrial Estate, Bental's, Basildon, Essex SS14 3BX

Tel +44 (0)8445 611 566

sales@Shalampackaging.com  
www.Shalampackaging.com

