

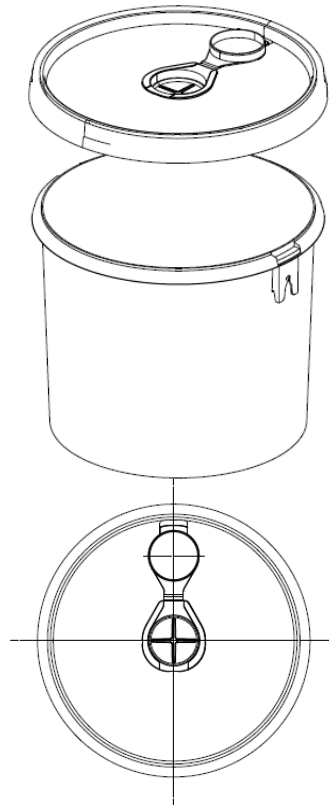

Shalam Packaging Ltd.

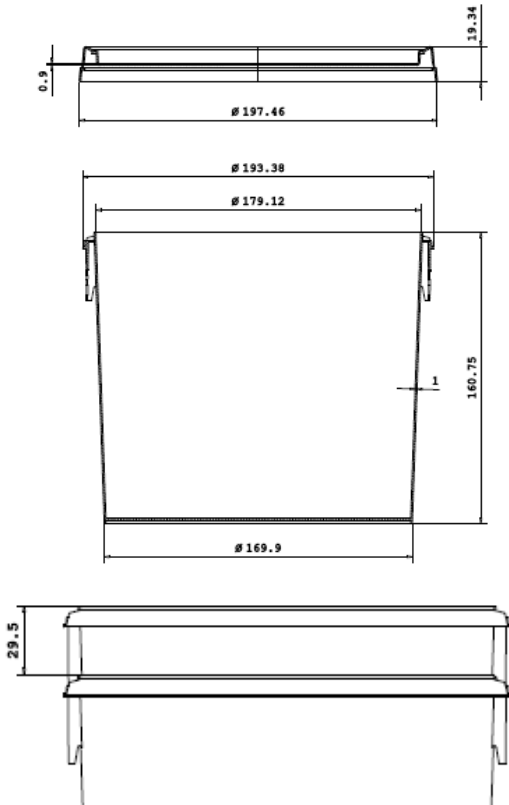

insert optional

# 3lt WET WIPE BUCKET

|  |   |
|--|---|
| MATERIAL   | Food Grade Polypropylene Co-Polymer   |
| HANDLE TYPE  | Plastic   |
| COLOUR   | White – a range of colours are available on request   |
| DECORATION   | In Mould Labeling available on request  |
| BRIM VOLUME  | 3.75 Litres   |
| WEIGHT   | Container: 110g (+/-5g)<br>Plastic handle: 7g (+/-1g)<br>Lid: 40g (+/-2g)<br>Insert Lid: 43g (+/-2g)  |
| QUANTITY (EMPTY)<br>PLT 1000MM X 1200MM                        | Container: 1,110 per pallet (30 stacks of 37), (1000mm x 1200mm)<br>Lid: 2,430 per pallet (30 stacks of 81)<br>Insert Lid: 2,100 per pallet (30 stacks of 70) |
| STACKING<br>(EMPTY)  | Container: 3 pallets high<br>Lid: 3 pallets high  |
| FILLING (Based on product density 1.4<br>air temperature 20°C) | 150 per pallet (30 per layer x 5 high)<br>This is equivalent to a maximum weight of 17kg on the lower bucket<br>1150 mm maximum pallet height                 |
| FILL TEMPERATURE   | Max 70°C (avoid prolonged exposure over 40°C and below 0°C)<br>Polymer blend can be adjusted to suit other temperatures.                                      |

Shalam Packaging Ltd., Pippis Hill Industrial Estate, Benthalls, Basildon, Essex SS14 3BX

Tel +44 (0)8445 611 566

sales@Shalampackaging.com  
www.Shalampackaging.com



*J. Meredith*

---

**COMPATIBILITY**

It is the responsibility of our customers to ensure their product is compatible with the container. Trials can be carried out by Shalam on request.

---

All details correct at the time of printing. Please contact us for additional technical, sales and order assistance.

