

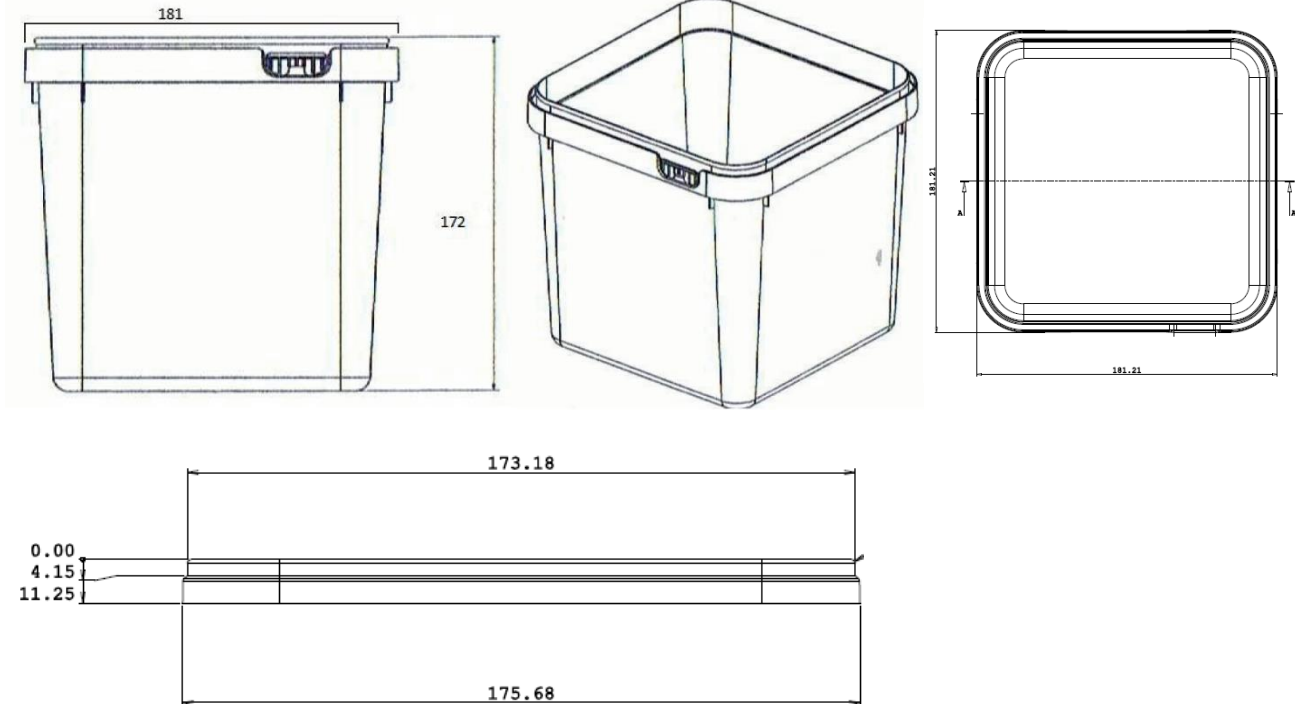

Shalam Packaging Ltd.



4ltr SQUARE TUB (1050) Tamper Evident

MATERIAL	Food Grade Polypropylene Co-Polymer	
COLOUR	White – a range of colours are available on request	
DECORATION	In Mould Labeling, for the lids, is available on request	
BRIM VOLUME	4.33 Litres	
WEIGHT	Container:	110g (+/- 6g)
	Lid:	27g (+/- 2 g)
QUANTITY (EMPTY)	Container:	1050 per pallet (1000mm x 1200mm)
	Lid:	4,950 per pallet Lids and buckets dairy wrapped for food standards
STACKING (EMPTY)	Container:	3 pallets high
	Lid:	in pallet box 3 high
FILLING (Based on product density 1.4 air temperature 20°C)	180 per pallet (30 per layer x 6 high) This is equivalent to a maximum weight of 28kg on the lower bucket 1150 mm maximum pallet height	
FILL TEMPERATURE	Max 70°C (avoid prolonged exposure over 40°C and below 0°C). Freezer grade max 50°C (avoid prolonged exposure over 40°C and below -20°C). Polymer blend can be adjusted to suit other temperatures.	
COMPATIBILITY	It is the responsibility of our customers to ensure their product is compatible with the container. Trials can be carried out by Shalam on request.	

All details correct at the time of printing. Please contact us for additional technical, sales and order assistance.

Shalam Packaging Ltd., Pippas Hill Industrial Estate, Benthalls, Basildon, Essex SS14 3BX

Tel +44 (0)8445 611 566

sales@Shalampackaging.com
www.Shalampackaging.com

