

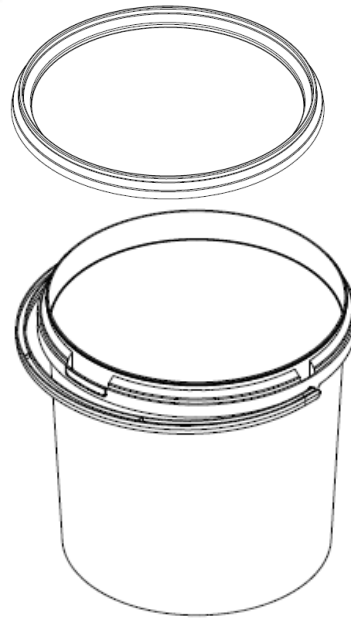

Shalam Packaging Ltd.

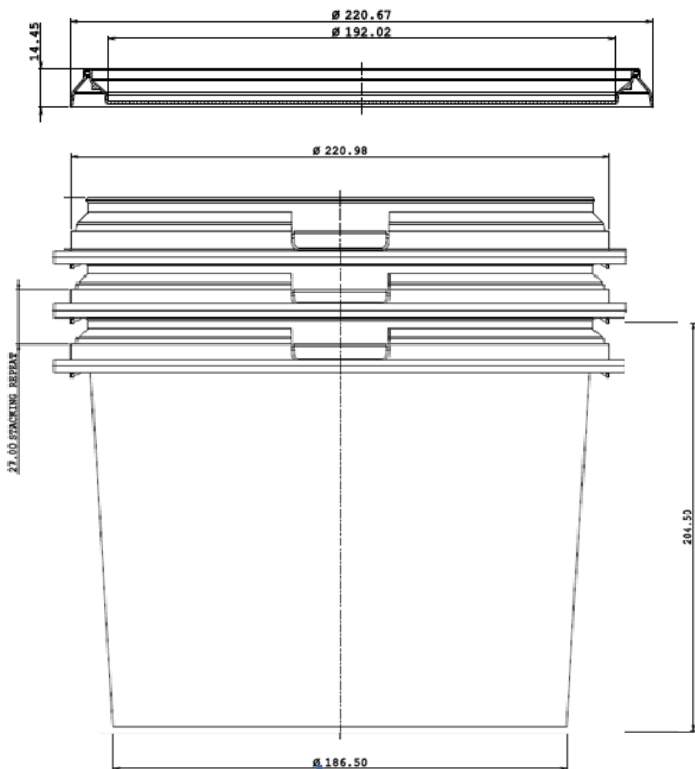

# 5ltr BUCKET MOULDS 2&3 Tamper Evident

<b>MATERIAL</b>	Food Grade Polypropylene Co-Polymer, option of recycled content. Polypropylene is a recyclable plastic.		
<b>HANDLE TYPE</b>	Plastic or metal		
<b>COLOUR</b>	White – a range of colours are available on request		
<b>DECORATION</b>	In Mould Labeling available on request		
<b>BRIM VOLUME</b>	6.09 Litres		
<b>WEIGHT</b>	<b>Container:</b>	<b>Virgin PP:</b>	<b>Recycled content PP (min 30%):</b>
	<b>Lid:</b>	162g (+/-9g)	178g (+/-14g)
	<b>Plastic handle:</b>	35.0g (+/-2g)	38.5g (+/-3g)
	<b>Metal handle:</b>	5.5g (+/- 1 g)	
		23.8g (+/- 2g)	
<b>QUANTITY</b> (Empty, pallet 1000mm by 1200mm)	<b>Container:</b>	1,000 Plastic handle (920 Metal Handle) per pallet	
	<b>Lid:</b>	3,910 per pallet	
		Lids and buckets can be dairy wrapped for food standards	
<b>STACKING</b> (Empty container or lid)	3 pallets high		
<b>FILLING</b> (Based on product density 1.4 air temperature 20°C)	<b>Plastic handle:</b>	125 per pallet (25 per layer x 5 high)	
	<b>Metal handle:</b>	120 per pallet (24 per layer x 5 high)	
		This is equivalent to a maximum weight of 28kg on the lower bucket	
		Maximum stacking temperature 40°C	
		1150 mm pallet height excluding pallet.	
<b>FILL TEMPERATURE</b> (Polymer blend can be adjusted to suit other temperatures)	<b>Standard:</b>	Max 60°C (avoid prolonged exposure over 40°C and below -20°C)	
	<b>Hotfill:</b>	Max 90°C (avoid prolonged exposure over 65°C and below 0°C)	
	<b>Extra hotfill:</b>	Max 121°C (avoid prolonged exposure over 100°C and below 10°C)	
	<b>Freezer:</b>	Max 50°C (avoid prolonged exposure over 30°C and below -30°C)	
<b>COMPATIBILITY</b>	It is the responsibility of our customers to ensure their product and processes are		

Shalam Packaging Ltd., Pippis Hill Industrial Estate, Benthalls, Basildon, Essex SS14 3BX

Tel +44 (0)8445 611 566

sales@Shalampackaging.com  
www.Shalampackaging.com



*J. Meredith*

compatible with the container. Trials can be carried out by Shalam on request.

---

All details correct at the time of printing. Please contact us for additional technical, sales and order assistance.

