

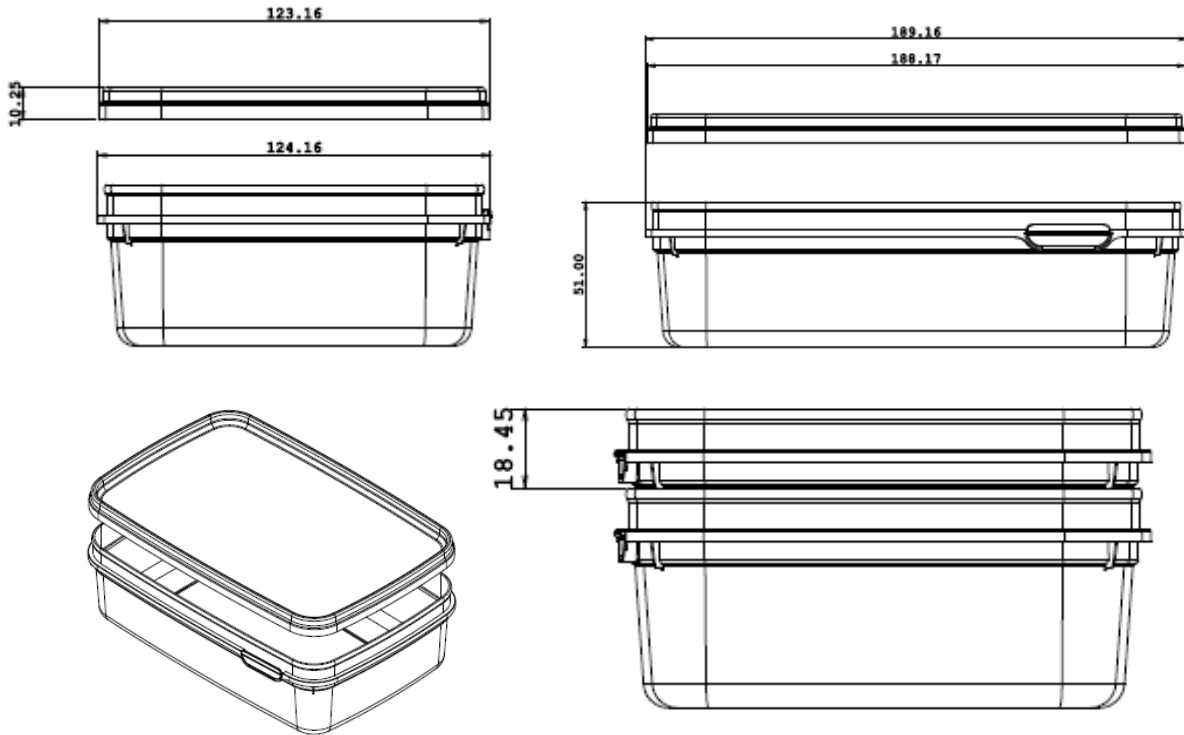

Shalam Packaging Ltd.



Nominal tub wall thickness 0.6+/-0.05 mm, nominal lid thickness 0.7+/-0.05 mm

800 ml TUB (3060)

Tamper Evident

MATERIAL	Food Grade Polypropylene Co-Polymer	
COLOUR	Natural, Black and White – a range of colours are available on request	
DECORATION	Lid In Mould Labeling available on request	
BRIM VOLUME	0.96L	
WEIGHT	Container:	32g (+/- 3g)
	Lid:	18.5g (+/- 2g)
QUANTITY (EMPTY)	Container:	3,060 per pallet (1000mm x 1200mm)
	Lid:	7,650 per pallet
	Lids and tubs dairy wrapped for food standards	
STACKING (EMPTY)	Container:	3 pallets high
	Lid:	in pallet box 3 high
FILLING (Based on product density 1.4 air temperature 20°C)	540 per pallet (45 per layer x 12 high) This is equivalent to a maximum weight of 12.5kg on the lower bucket 630 mm maximum pallet height.	
FILL TEMPERATURE	Max 70°C (avoid prolonged exposure over 40°C and below 0°C) Hot fill max 121°C (avoid prolonged exposure over 100°C and below 5°C) Freezer grade max 70°C (avoid prolonged exposure over 40°C and below -20°C). Polymer blend can be adjusted to suit other temperatures. Do not stack hot.	
COMPATIBILITY	It is the responsibility of our customers to ensure their product is compatible with the container. Trials can be carried out by Shalam on request.	

All details correct at the time of printing. Please contact us for additional technical, sales and order assistance.

Shalam Packaging Ltd., Pippis Hill Industrial Estate, Benthalls, Basildon, Essex SS14 3BX

Tel +44 (0)8445 611 566

sales@Shalampackaging.com
www.Shalampackaging.com

