

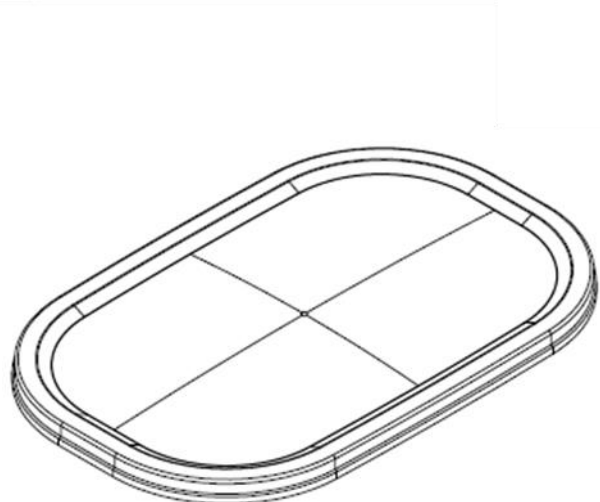

Shalam Packaging Ltd.

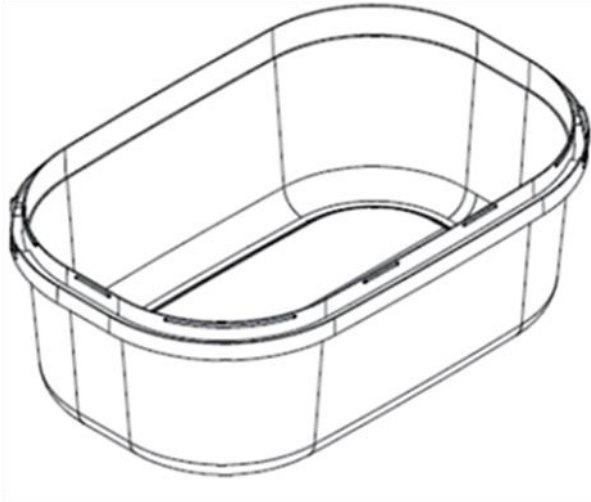

Tub length	196.8	mm
Tub width	129.8	mm
Tub height	68.0	mm
Lid height	8.0	mm

1 LTR SQUARE OVAL TUB

Tamper Evident

MATERIAL	Food Grade Polypropylene Co-Polymer	
COLOUR	Natural, or clear – a range of colours are available on request	
DECORATION	IML Available on Lid and Base	
BRIM VOLUME	1.24 L	
WEIGHT	Container:	35g (+/- 2g)
	Lid:	17g (+/- 1g)
QUANTITY (EMPTY)	Container:	2,250 per pallet (1000mm x 1200mm)
	Lid:	15,840 per pallet
STACKING (EMPTY)	Container:	3 pallets
	Lid:	high in pallet box 3 high
FILLING (Based on product density 1.4 air temperature 20°C)	360 per pallet (45 per layer x 8 high) This is equivalent to a maximum weight of 10 kg on the lower tub 700 mm maximum pallet height.	
FILL TEMPERATURE	Max 70°C (avoid prolonged exposure over 40°C and below -25°C) Polymer blend can be adjusted to suit other temperatures.	
COMPATIBILITY	It is the responsibility of our customers to ensure their product is compatible with the container. Trials can be carried out by Shalam on request.	

All details correct at the time of printing. Please contact us for additional technical, sales and order assistance.

Shalam Packaging Ltd., Pippis Hill Industrial Estate, Bentalhs, Basildon, Essex SS14 3BX

Tel +44 (0)8445 611 566

sales@Shalampackaging.com
www.Shalampackaging.com

