

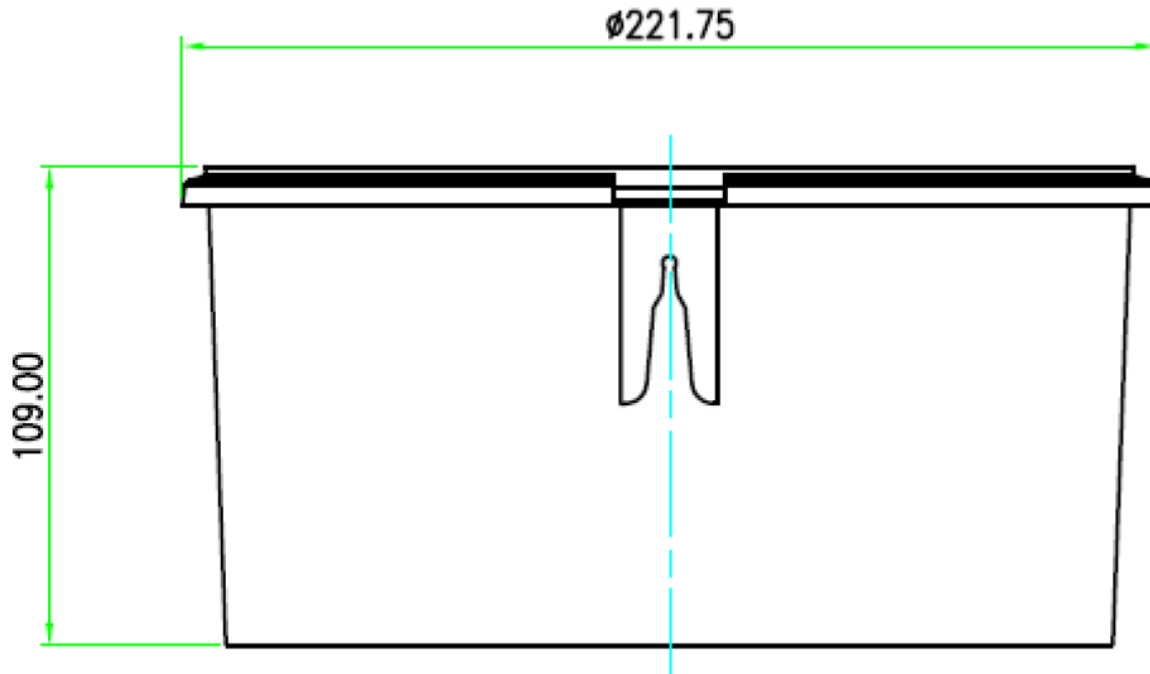

Shalam UK Ltd



## 3ltr INK BUCKET

<b>MATERIAL</b>	Food Grade Polypropylene Co-Polymer
<b>HANDLE TYPE</b>	Plastic
<b>COLOUR</b>	Black – a range of colours are available on request
<b>DECORATION</b>	No decoration available
<b>WEIGHT</b>	<b>Container:</b> 110g (+/- 8g) <b>Lid:</b> 50g (+/- 4 g)
<b>QUANTITY (EMPTY)</b>	<b>Container:</b> 480 per pallet (Pallet 1000mm x 1200mm) <b>Lid:</b> 1200 per pallet (60 per stack)
<b>STACKING (EMPTY)</b>	<b>Container:</b> 2 pallets high <b>Lid:</b> In pallet box 3 high
<b>FILLING</b> (Based on product density 1.4 air temperature 20°C)	140 per pallet (20 per layer x 7 high) (1000mm x 1200mm)
<b>FILL TEMPERATURE</b>	Max 70°C (avoid prolonged exposure over 40°C and below 0°C)
<b>COMPATIBILITY</b>	It is the responsibility of our customers to ensure their product is compatible with the container. Trials can be carried out by Shalam on request. Stacking performance is affected by temperature, Do not stack hot.

All details correct at the time of printing. Please contact us for additional technical, sales and order assistance.

Shalam Packaging Ltd., Pippis Hill Industrial Estate, Benthalls, Basildon, Essex SS14 3BX Tel +44 (0)8445 611 566

[sales@Shalampackaging.com](mailto:sales@Shalampackaging.com)  
[www.Shalampackaging.com](http://www.Shalampackaging.com)

