

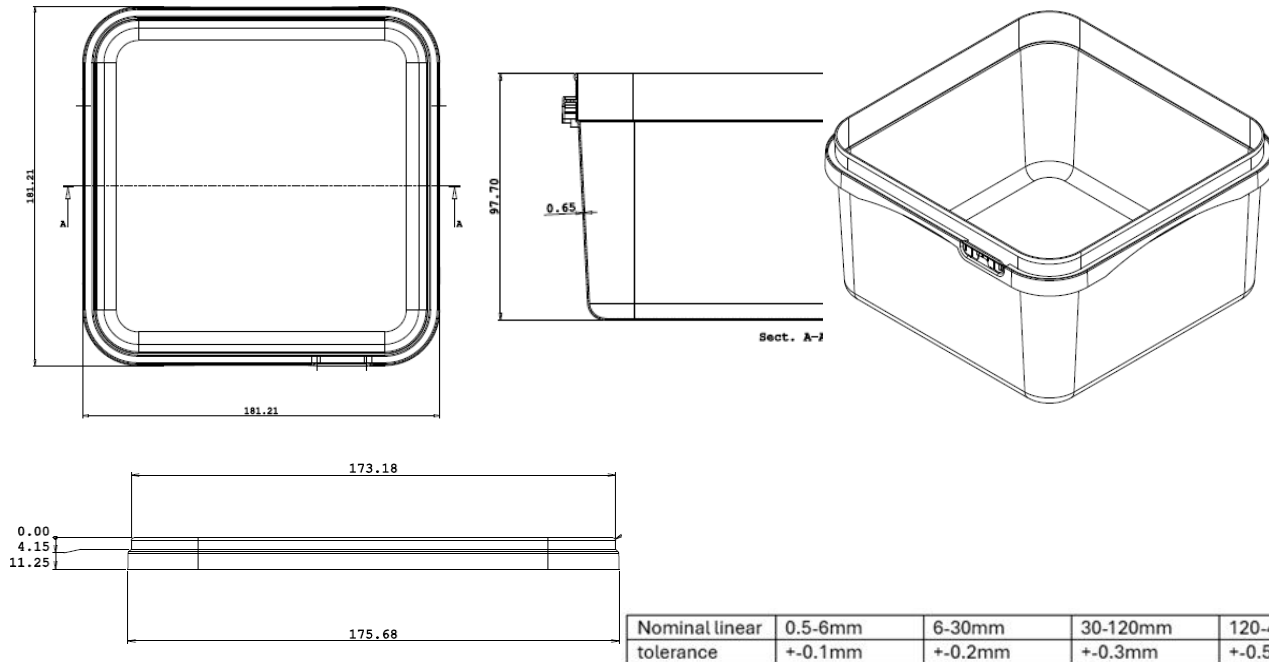

Shalam Packaging Ltd.



2.4ltr SQUARE TUB (1680)

Tamper Evident

MATERIAL	Food Grade Polypropylene Co-Polymer
COLOUR	White – a range of colours are available on request including natural and clear
DECORATION	In Mould Labeling is available on request
BRIM VOLUME	2.58 Litres
WEIGHT	<p>Container: 55g (+/- 4g) mould 4 71g (+/- 5g) other moulds</p> <p>Lid: 27g (+/- 2g)</p>
QUANTITY (EMPTY)	<p>Container: 1680 per pallet (1000mm x 1200mm) 2,670 per pallet container specification</p> <p>Lid: 4,950 per pallet Lids and buckets dairy wrapped for food standards</p>
STACKING (EMPTY)	<p>Container: 2 pallets high</p> <p>Lid: in pallet box 3 high</p>
FILLING (Based on product density 1.4 air temperature 20°C)	<p>180 per pallet (30 per layer x 6 high)</p> <p>This is equivalent to a maximum weight of 18kg on the lower bucket</p> <p>1150 mm maximum pallet height</p>
FILL TEMPERATURE (Polymer blend can be adjusted to suit other temperatures)	<p>Standard: Max 70°C (avoid prolonged exposure over 40°C and below 0°C)</p> <p>Hotfill: Max 121°C (avoid prolonged exposure over 100°C and below 10°C)</p> <p>Freezer: Max 50°C (avoid prolonged exposure over 40°C and below -40°C)</p>
COMPATIBILITY	It is the responsibility of our customers to ensure their product is compatible with the container. Trials can be carried out by Shalam on request.

All details correct at the time of printing. Please contact us for additional technical, sales and order assistance.

Shalam Packaging Ltd., Pippis Hill Industrial Estate, Tel +44 (0)8445 611 566
Bentalls, Basildon, Essex SS14 3BX

sales@Shalampackaging.com
www.Shalampackaging.com

